

LEAP AHEAD! *Low Humidity* Dehumidifiers

LGR 7000 XLI
95 LITRES/DAY

INLET 27% 28% OUTLET 36% 8%

£3.38 9.8 KgCo₂e 58 L @ £0.058/L



REVOLUTION LGR
63 LITRES/DAY

£2.88 8.4 KgCo₂e 36 L @ £0.080/L

MORE...

- » SUSTAINABLE DRYING
 - » EQUIPMENT UTILISATION
 - » DRYING INTELLIGENCE

LESS...

- » DRYING TIME
- » ENVIRONMENTAL IMPACT
 - » PROCESS HUMIDITY

Widest operating range for Restorative Drying



Restoration Sciences
ACADEMY

Psychrometric Chart

At Sea Level

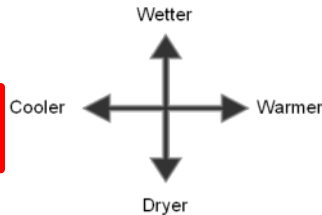

Ideal Drying

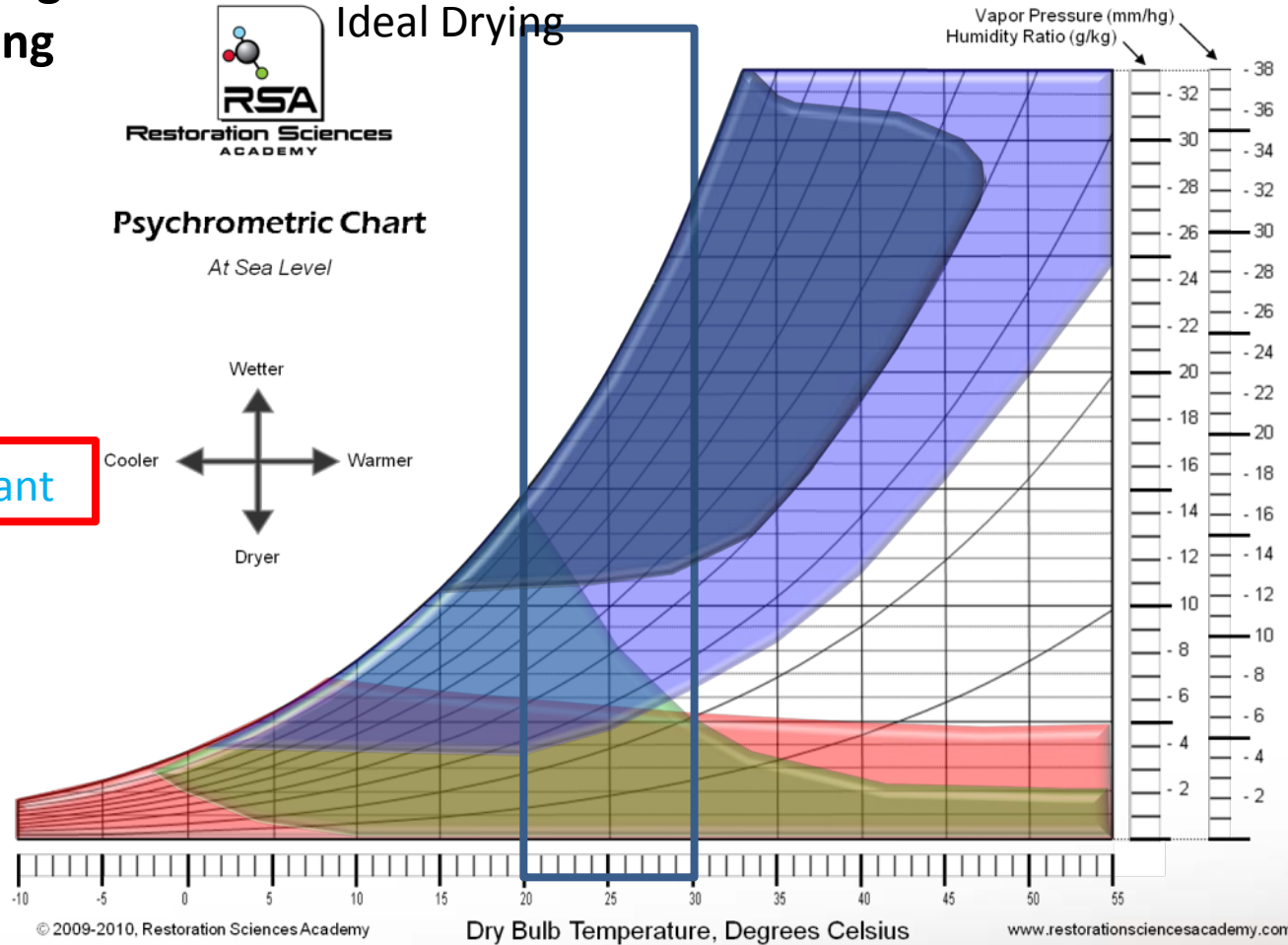

Standard Refrigerant

Low Humidity Refrigerant

Desiccant

Heat and Air Exchange

Improved Performance

Why not take a look at our new 2014 brochure which is full of equipment comparison information designed to help drive efficient, effective drying

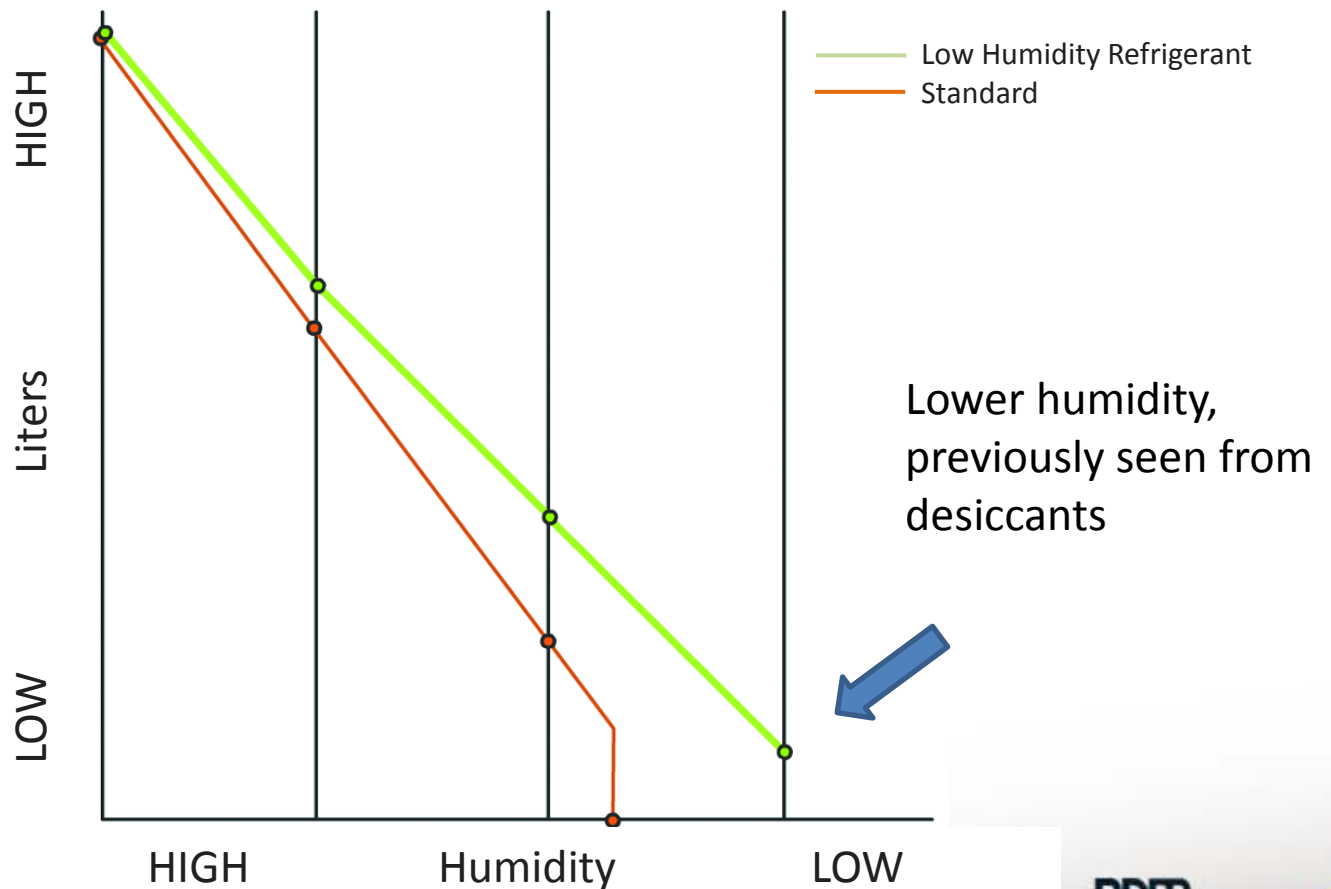

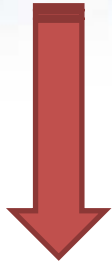

Drying Time
Environmental Impact
Energy Consumption

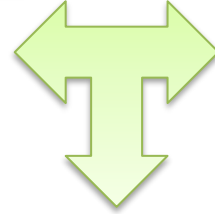

Client Satisfaction
Cost effectiveness
Equipment Flexibility
Return on investment

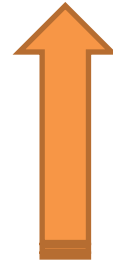

Low Humidity Refrigerant



Standard Refrigerant



Desiccant



Open the Windows

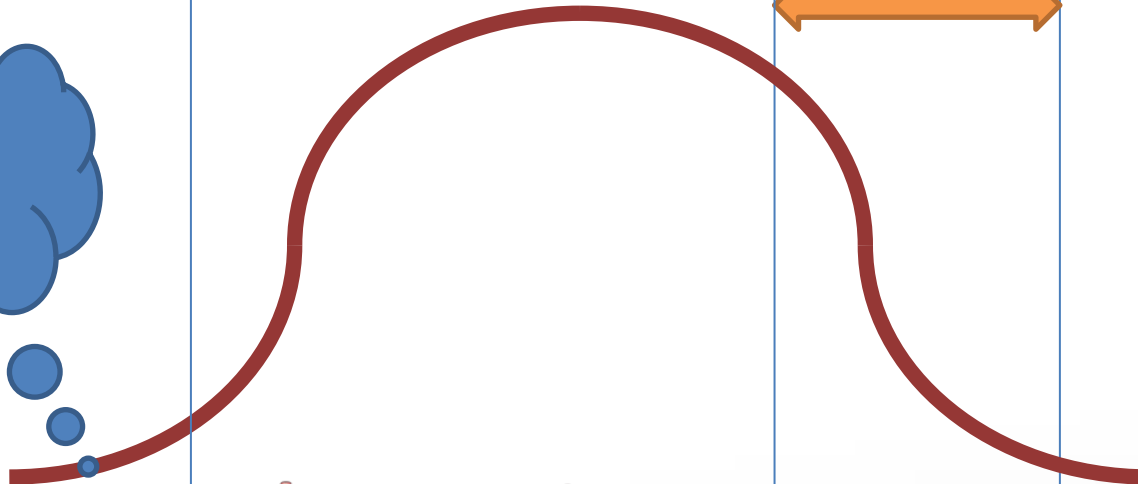

Nature / Scope of Drying Situation

Drying Dense Materials with Bound Water

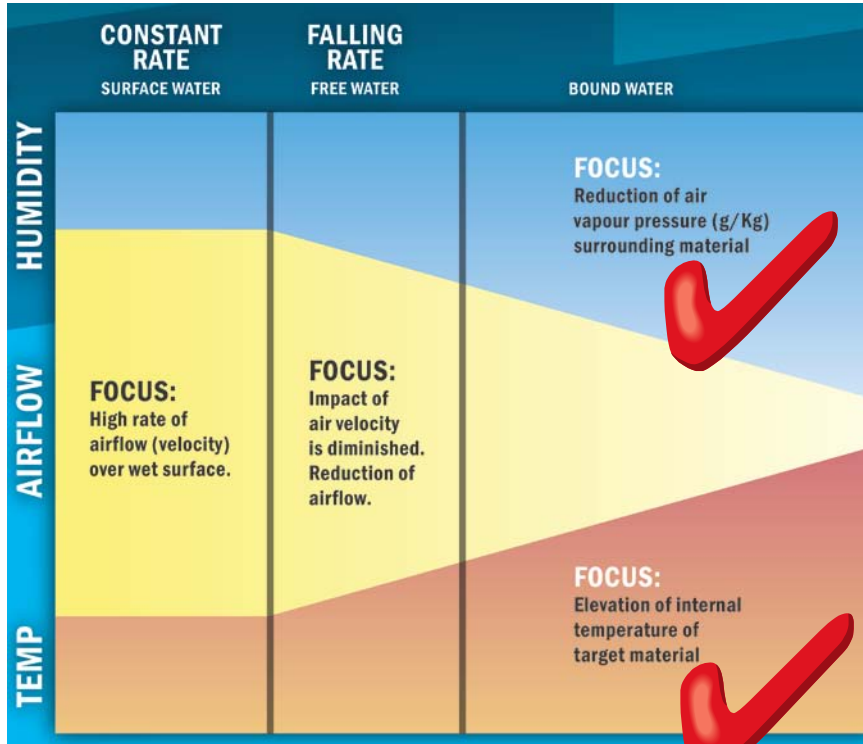

Use warmed, low humidity processed air to drive drying during later stages and focus output using tent.

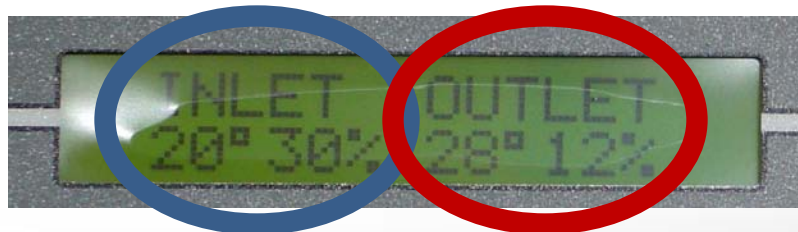



Just Arrived!



63L capacity
1/2 the size of LGR1800
More Intelligent
Lower running costs



The Revolution LGR

- The smallest, lightest “Large” category dehu ever!
- Best low humidity performance in its class
- Secure, compact stacking
- Easiest to transport multiple units
- Fastest access for cleaning & maintenance





Revolution: What are the benefits?

- Fit 2-3 times the dehumidification on the van
- Fewer trips back to the shop
- Smaller vans, better fuel mileage
- Improved return on investment
- Simpler design + faster maintenance = dehu runs better, longer

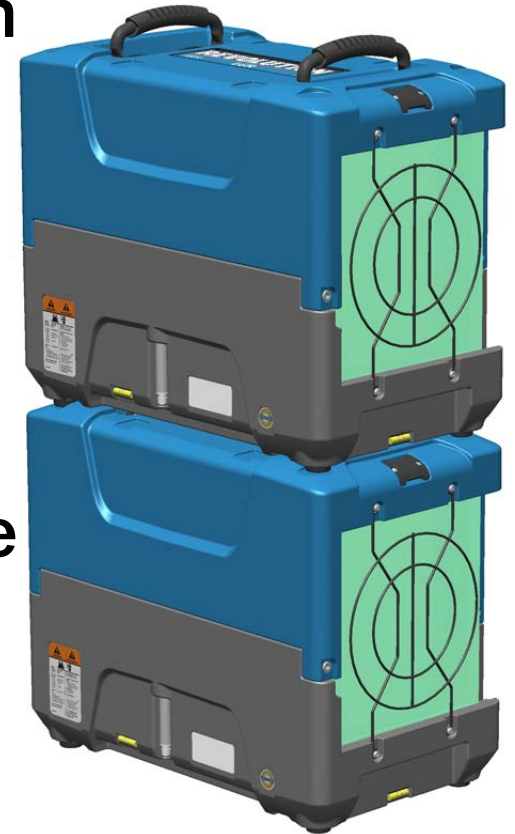

Large performance in a small package!

Patent-pending **Precision** Control Technology

- Uses software to optimise performance at various conditions
- Sensors + software drive **fan speed** and **defrost system** adjustments to maximise water removal
- No heat exchange block + simple mechanical design = easy maintenance

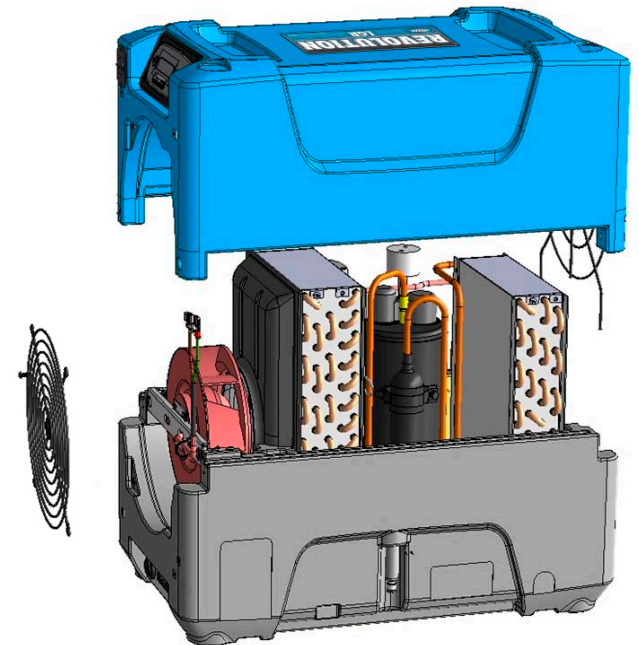

Durable digital touchpad, humidistat

- i-Series recessed display shows:
 - job hours
 - inlet/outlet temperature and relative humidity
 - digital humidistat
 - clear status messages in 4 languages (English, Spanish, French & German)

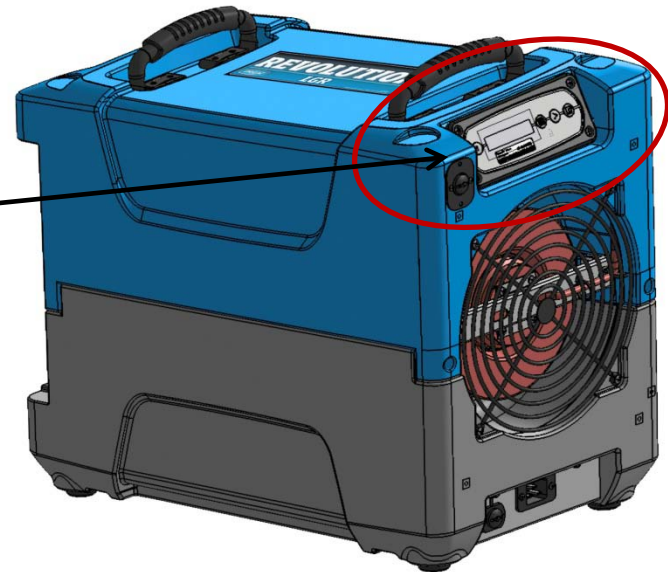

Easiest to Maintain

Remove eight bolts & lift off cover to access internal components for cleaning & service – in just a few minutes!

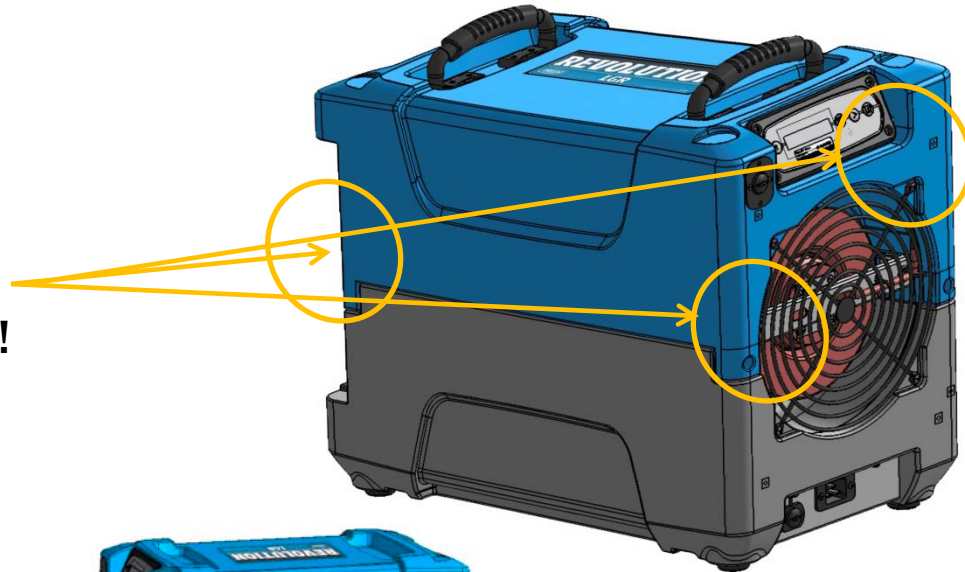

Top-down view of components in bottom housing

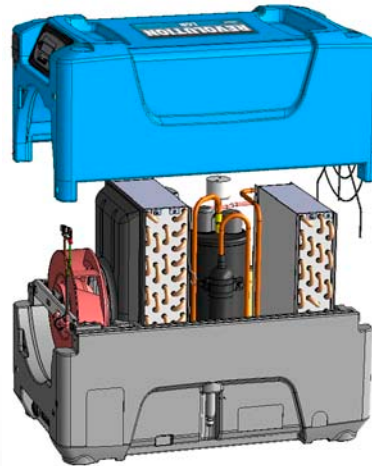
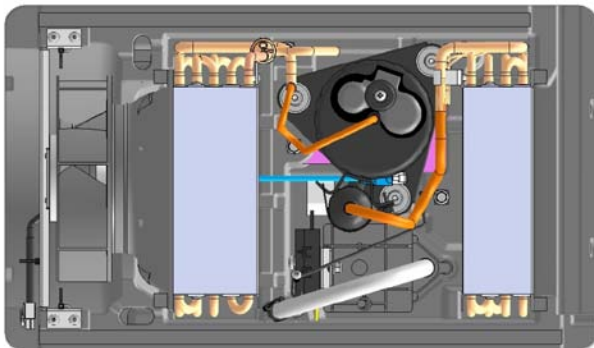

Stackable – Nests for Secure Transport

Feet sit firmly
in “well”
moulded in
housing

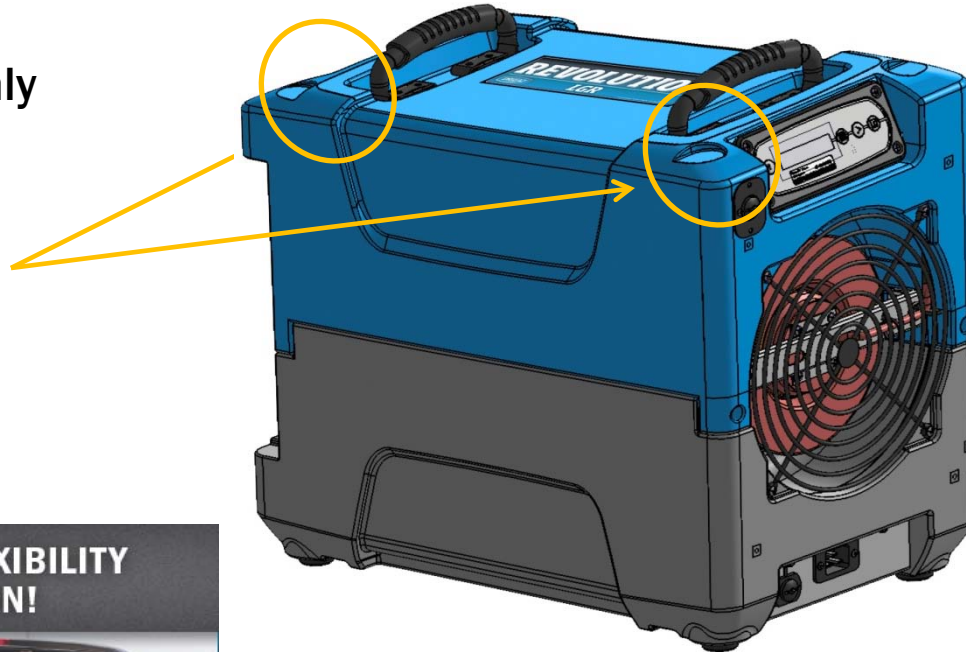

**PACK MORE FLEXIBILITY
IN YOUR VAN!**



Stack at least 2
units securely on
standard
handtruck for
easy transport

LGR7000Xi

Intelligent portable drying system

- Ground Breaking advancements:
 - XL water removal rate
 - Advanced ‘cross-flow’ technology
 - Self monitoring
 - Improved ‘focus’ drying capability
 - Higher airflow
 - Energy and Environmentally efficient
 - Lower weight, smaller size



- **Advanced ‘Cross-flow’ technology**

- Pre-cools ‘wet’ incoming air
- Increases ‘dry’ outgoing air temp
- ‘Recycles’ heat energy, doesn’t waste it!
- Maximises energy efficiency

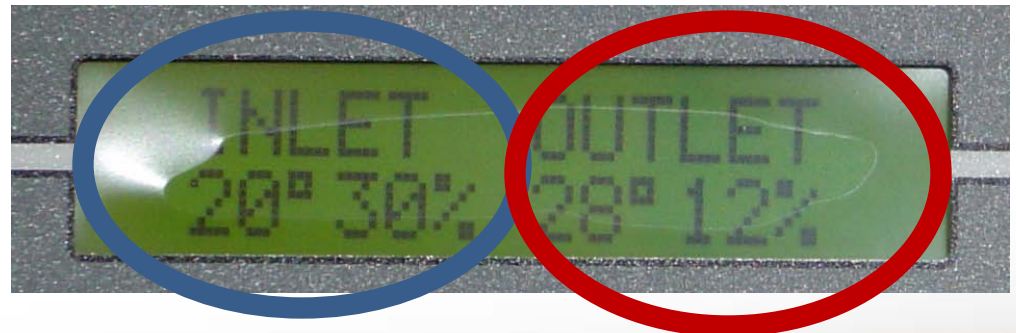
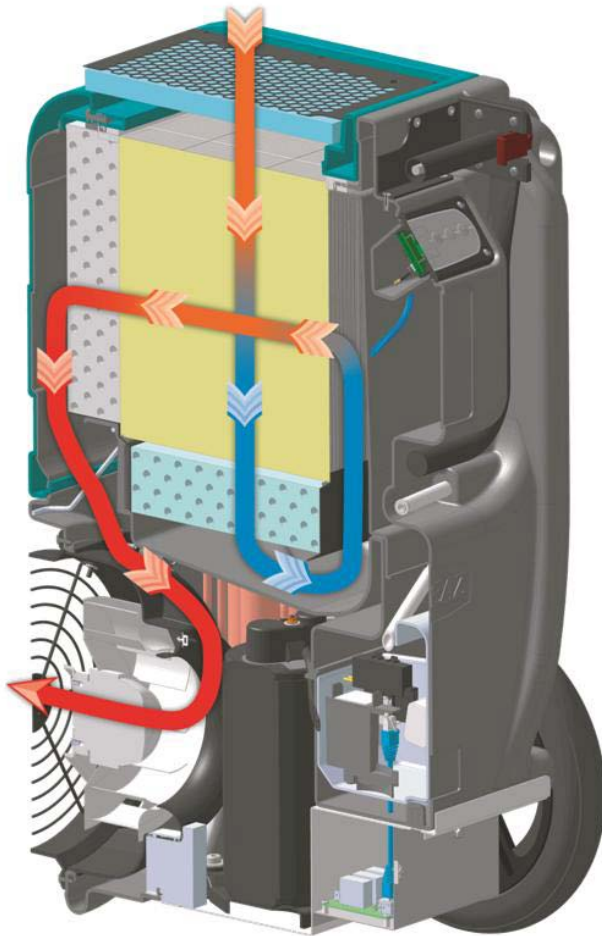



Flexible Drying System



Additional
Sensors

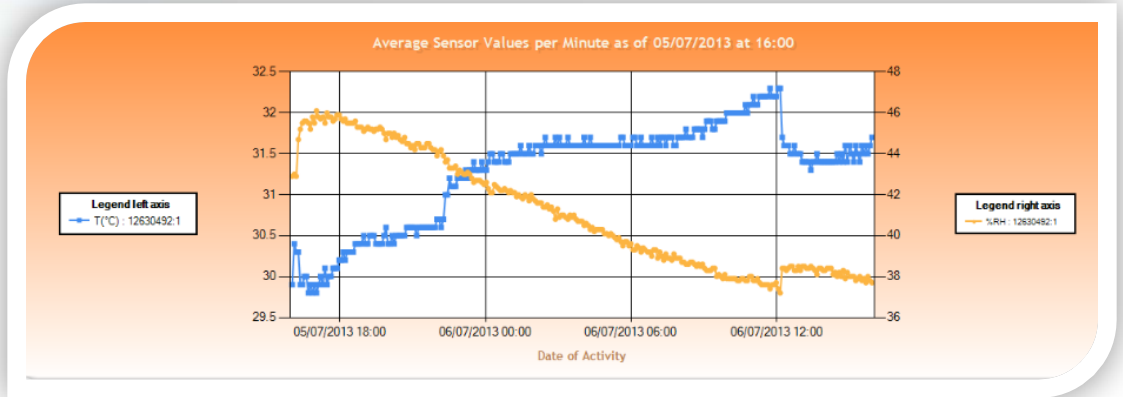

DriFi
Intelligent drying...joined up thinking

